

# juicedLink™

## User's Manual

### DT454 – XLR Adapter / Preamplifier / AGC Disabler



## Contents

*Click on heading to jump to page ...*

|   |           |
|---|-----------|
| <b>Contents</b> .....   | <b>2</b>  |
| <b>Read This First</b> .....  | <b>4</b>  |
| <b>Warnings - General</b> .....                                     | <b>4</b>  |
| <b>General</b> .....  | <b>5</b>  |
| <b>Features / Specifications</b> .....                              | <b>5</b>  |
| <b>Switch / Panel Descriptions and Photos</b> .....                 | <b>6</b>  |
| <b>Photos</b> .....   | <b>6</b>  |
| <b>Front Panel Switches</b> .....                                   | <b>8</b>  |
| <b>Side / Back Inputs</b> .....                                     | <b>9</b>  |
| <b>Bottom Switches</b> .....  | <b>10</b> |
| <b>Included Items</b> .....   | <b>12</b> |
| <b>Accessories</b> .....  | <b>12</b> |
| <b>Block Diagram (Basic)</b> .....                                  | <b>13</b> |
| <b>Basic Operation</b> .....  | <b>14</b> |
| <b>Mounting to Camera</b> .....                                     | <b>14</b> |
| <b>Mounting to Tripod</b> .....                                     | <b>15</b> |
| <b>Output Connection to Camera</b> .....                            | <b>16</b> |
| <b>Powering</b> .....   | <b>17</b> |
| <b>Alkaline Battery Life</b> .....                                  | <b>17</b> |
| <b>Rechargeable Batteries</b> .....                                 | <b>17</b> |
| <b>Input Connections</b> .....                                      | <b>18</b> |
| <b>TIP-L / RING-R Unbalanced Input</b> .....                        | <b>18</b> |
| <b>XLR-L / XLR-R Balanced Input</b> .....                           | <b>19</b> |
| <b>XLR-L / XLR-R with Unbalanced Sources (Wireless, Etc.)</b> ..... | <b>19</b> |
| <b>Phantom Power</b> .....  | <b>20</b> |
| <b>MIC/LINE Switches</b> .....                                      | <b>22</b> |
| <b>MONO / STEREO Switch</b> .....                                   | <b>23</b> |
| <b>PAN TO L / NORM</b> .....  | <b>24</b> |
| <b>GAIN Settings</b> .....  | <b>25</b> |
| <b>TRIM Potentiometers</b> .....                                    | <b>26</b> |
| <b>Camcorder Settings</b> .....                                     | <b>27</b> |
| <b>Low-Noise Performance</b> .....                                  | <b>27</b> |

|   |           |
|---|-----------|
| <b>Dynamic Range Performance</b> .....                          | <b>27</b> |
| <b>AGC Disable</b> .....  | <b>28</b> |
| <b>Tone</b> .....   | <b>29</b> |
| <b>Safety Mode – Noise</b> .....                                | <b>30</b> |
| <b>Metering: Setting the Appropriate Gain/Trim Levels</b> ..... | <b>32</b> |
| <b>Headphone Monitoring</b> .....                               | <b>34</b> |
| <b>Playback Headphone Monitoring</b> .....                      | <b>34</b> |
| <b>Notes on Specific Cameras</b> .....                          | <b>35</b> |
| <b>Canon 5D Mark II</b> .....                                   | <b>35</b> |
| <b>Firmware Release 2.0.4</b> .....                             | <b>35</b> |
| <b>MagicLantern 3<sup>rd</sup> Party Firmware</b> .....         | <b>36</b> |
| <b>Advanced Topics</b> .....                                    | <b>37</b> |
| <b>Post Production – Removing Tone</b> .....                    | <b>37</b> |
| <b>Post Production – Removing Right Track</b> .....             | <b>38</b> |
| <b>Appendix</b> .....   | <b>40</b> |
| <b>Subscribe to the juicedLink Blog</b> .....                   | <b>40</b> |
| <b>Care and Maintenance</b> .....                               | <b>40</b> |
| <b>Warranty, Service, and Returns</b> .....                     | <b>40</b> |
| <b>Compliance</b> .....   | <b>40</b> |

## ***Read This First***

Before operating the unit, please read this manual thoroughly.

Any future revisions will be posted on the website and available for download.

Get notified on new revisions of this User Manual, product updates, new product releases, and tutorial videos. Subscribe to the blog:

[www.juicedlink.com/blog/index.html](http://www.juicedlink.com/blog/index.html)

Notes regarding documentation in this manual are as follows:

- References to markings/labels on the unit are denoted in underline/bold. For example: **HPF**.
- Warnings will be preceded with **WARNING**.

### ***Warnings - General***

**WARNING:** Failure to read and observe notes and warnings may result in personal injury, and/or possible damage to this device and your other equipment.

**WARNING - LOSS OF HEARING:** This device, as well as any device with a headphone amplifier, is capable of driving the signal at levels that can be damaging to hearing. Always operate the headphone volume at the lowest practical level. Do not wear the headphones over your ears in any of the following circumstances:

- While plugging the headphones into the headphone driving device.
- While plugging the mixer into the headphone driving device.
- While turning on or off the mixer.
- While turning on or off the phantom power.
- While plugging a device into the input of the mixer.

**WARNING - RISK OF ELECTRICAL SHOCK:** This device, its enclosure, and the connections to cable shields that plug into this device are conductive. Avoid electrocution and observe caution with cable runs near areas where high-voltages and/or currents may exist.

### **Features / Specifications**

- General Features
  - 4 microphone channels (2 XLR, 2 unbalanced)
  - Meters
    - 4 segment LED (each right/left)
    - 2 sensitivity settings (high/low); adjustable for calibration
    - valuable for new 5D firmware (where meters are not visible during recording)
  - 2 AGC Disable choices
    - Tone
    - Safety mode (broadband noise)
  - 30dB low noise max gain (single ended, stereo)
    - This is even more available max gain than the CX family of preamps
    - This is additional gain is very valuable with the new Canon 5D 2.0.4 firmware release, as well as MagicLantern users
  - Headphones
  - Playback Monitor
  - 48V phantom, plus 12V phantom power saving mode
  - Low-noise preamp (see THAT1512 datasheet for details on XLR preamp)
  - Power:
    - Single 9V Alkaline or Li-polymer battery (not included)
    - See “Powering” Section for more details
  - Mechanical:
    - Black Anodized Aluminum enclosure for EMI protection and rugged use
    - Mounts to bottom of camera and top of tripod
    - Case Dimensions: 4.5” x 3.2” x 1.5”
    - Weight: 10 ounces (no battery)
  - Includes: Stereo 3.5mm miniplug cable, 1/8” Allen wrench key

Features and Specifications are subject to change without notice.

Return to [Contents](#)

## Switch / Panel Descriptions and Photos

### Photos



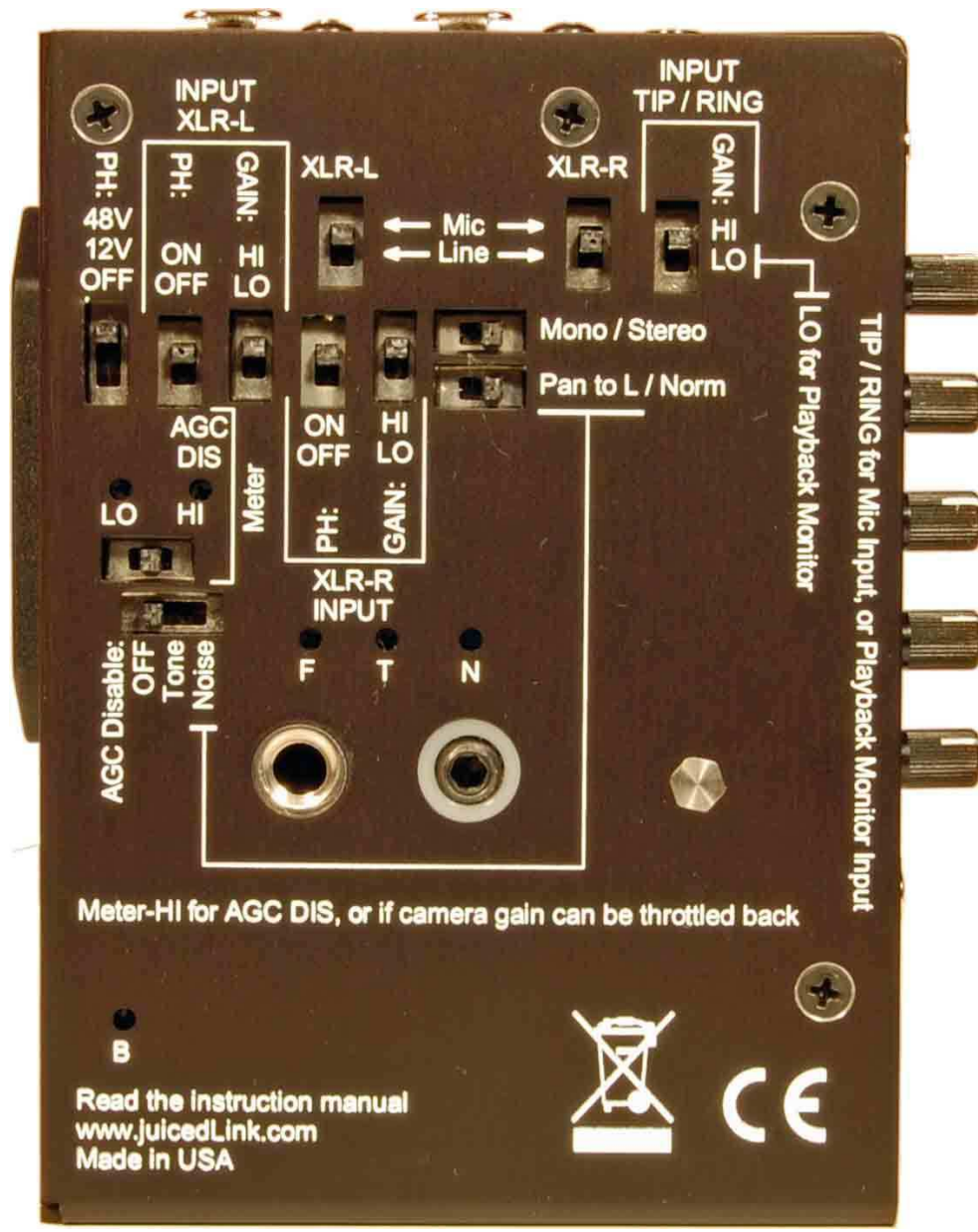

Return to [Contents](#)

## Front Panel Switches

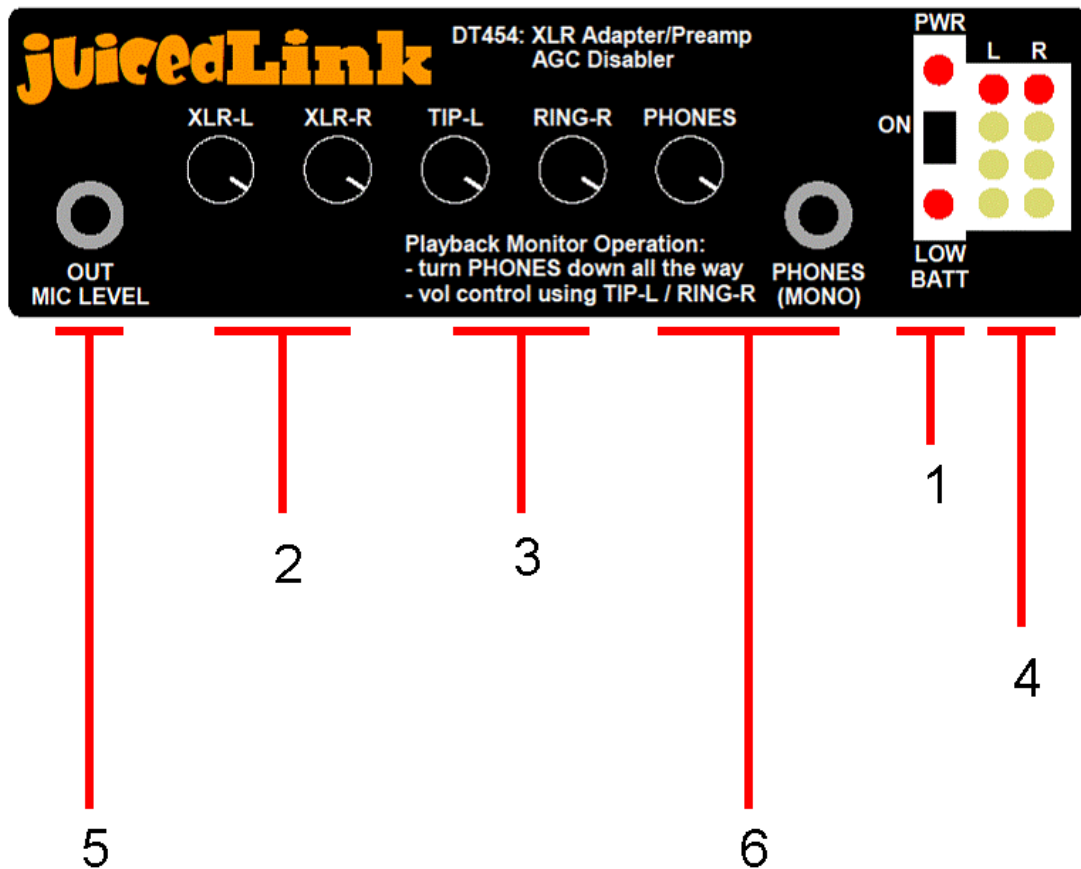

1. **ON** / OFF switch, **PWR** indicator LED, **LOW BATT** low battery indicator LED
2. **TRIM** controls for **XLR-L** and **XLR-R** microphone (or line) input channels
3. **TRIM** controls for **TIP-L** and **RING-R** microphone (or playback monitor) input channels
4. Left (**L**) and Right (**R**) channel signal level meters
5. Output (**OUT**) at an amplified mic level, which connects to the microphone input of your camera through a stereo minijack cable (included)
6. Headphone (**PHONES**) minijack output and volume control

Return to [Contents](#)

## Side / Back Inputs

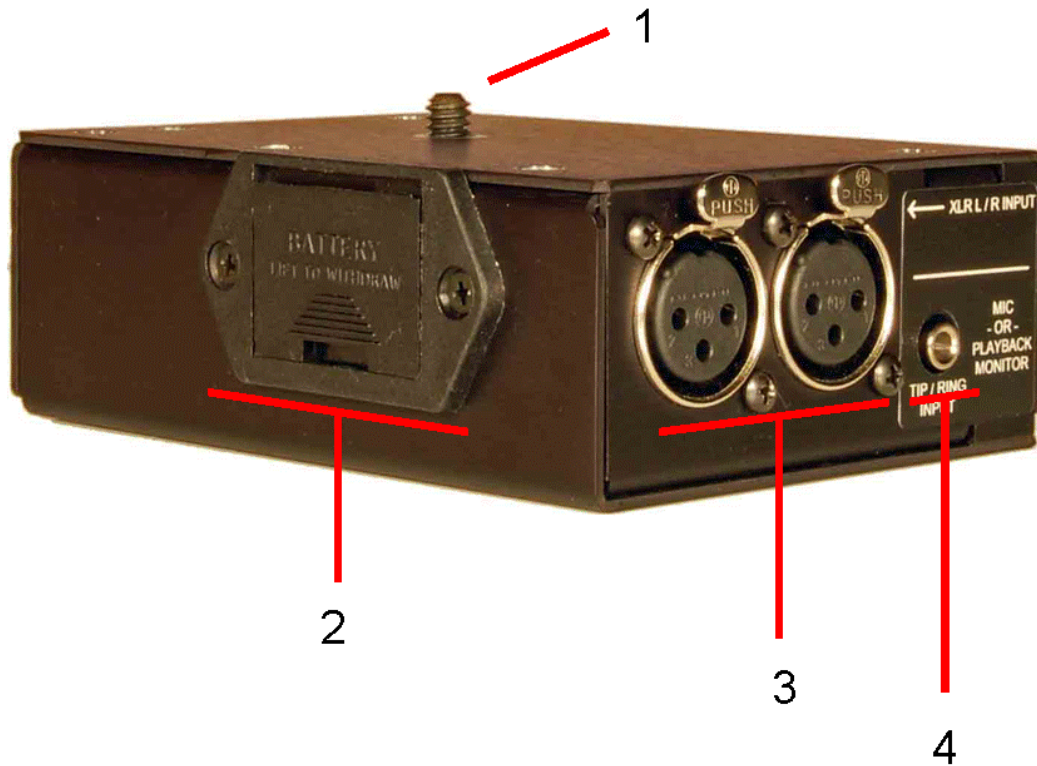

1. Camera mounting screw (1/4-20)
  - a. USE HEX KEY (included) and insert into the bottom of the screw to rotate the screw into the camera threads to mount to camera
2. 9V battery tray
3. Audio Inputs: **XLR-L** (left) and **XLR-R** (right) balanced mic or line inputs (unbalanced capable)
4. Audio Inputs: **TIP-L** (left) and **RING-R** (right) unbalanced mic inputs (or playback monitor inputs)

Return to [Contents](#)

# Bottom Switches

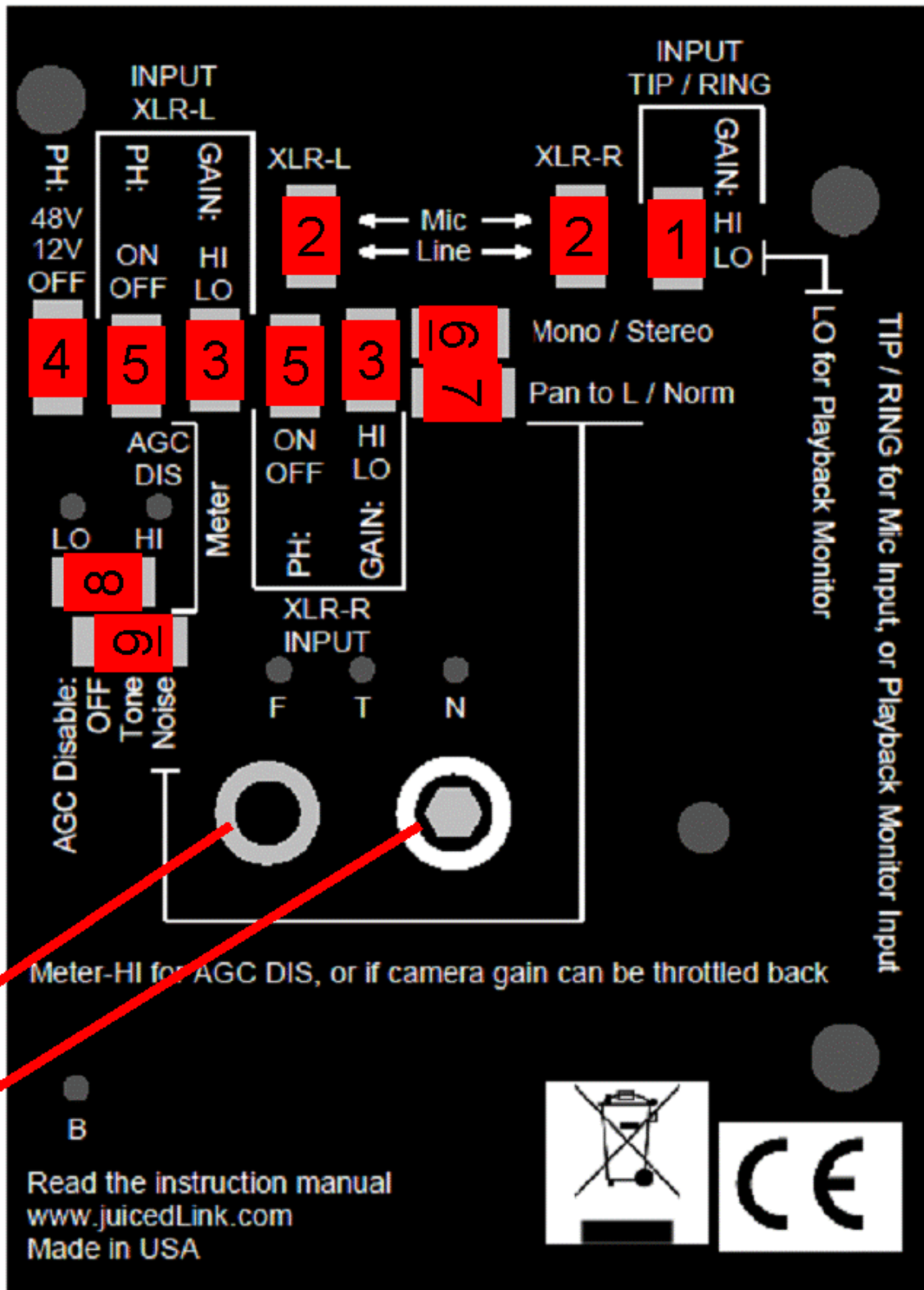

1. **GAIN** switch (**HI** / **LO**) for **TIP-L** / **RING-R** unbalanced inputs
  - a. Use **LO** setting when input is being used as a Playback Monitor
2. **MIC** / **LINE** switch settings for **XLR-L** / **XLR-R** balanced inputs
3. **GAIN** switch (**HI** / **LO**) for **XLR-L** / **XLR-R** balanced inputs
4. Phantom (**PH**) power switch. Generates either **48V** or **12V** in the power supply circuitry.
  - b. Phantom voltage is not applied to the XLR input until the **PH: ON / OFF** switch is set to **ON** for the corresponding **XLR-L** / **XLR-R** balanced input
  - c. Mics which work from 12V phantom power can considerably extend battery life
5. **PH: ON / OFF** switch routes the phantom voltage generated by the power supply circuit to the corresponding **XLR-L** / **XLR-R** balanced input
  - d. Only apply phantom power to condenser mics which require phantom voltage
  - e. Never apply phantom power to unbalanced mic sources (wireless mics, etc.) or mixing boards.
6. **MONO** combines the right and left inputs and presents the combination to each of the right and left outputs. **STEREO** leaves the right and left inputs separated, and only the corresponding input signal is presented to each of the right and left outputs.
7. **PAN TO L** combines the right and left input channels, and presents the combination to the left output channel.
8. Meter sensitivity switch
  - f. **HI** to be used when either you have manual control of the camera gain, and have throttled back its noisy gain, or if your are using the AGC Disable feature of the DT454 to force the camera gain to throttle back. This setting is most commonly used for typical operation.
  - g. **LO** setting when camera AGC is running with no efforts to throttle it back
9. **AGC DISABLE** feature of the DT454, to improve signal to noise performance on cameras which do not have manual control
  - h. **TONE** injects a ~20kHz tone into the camera's right track, to spoof its
  - i. Safety Mode **NOISE** AGC Disable approach injects a broadband noise signal into the camera's right track to spoof its AGC algorithm into throttling back its noisy gain.
10. ¼-20 thread for mounting DT454 on top of a tripod (etc).
11. Hex key receptacle. USE HEX KEY (included) HERE TO TURN ¼-20 SCREW INTO CAMERA FOR MOUNTING TO BOTTOM OF CAMERA.

Return to [Contents](#)

## ***Included Items***

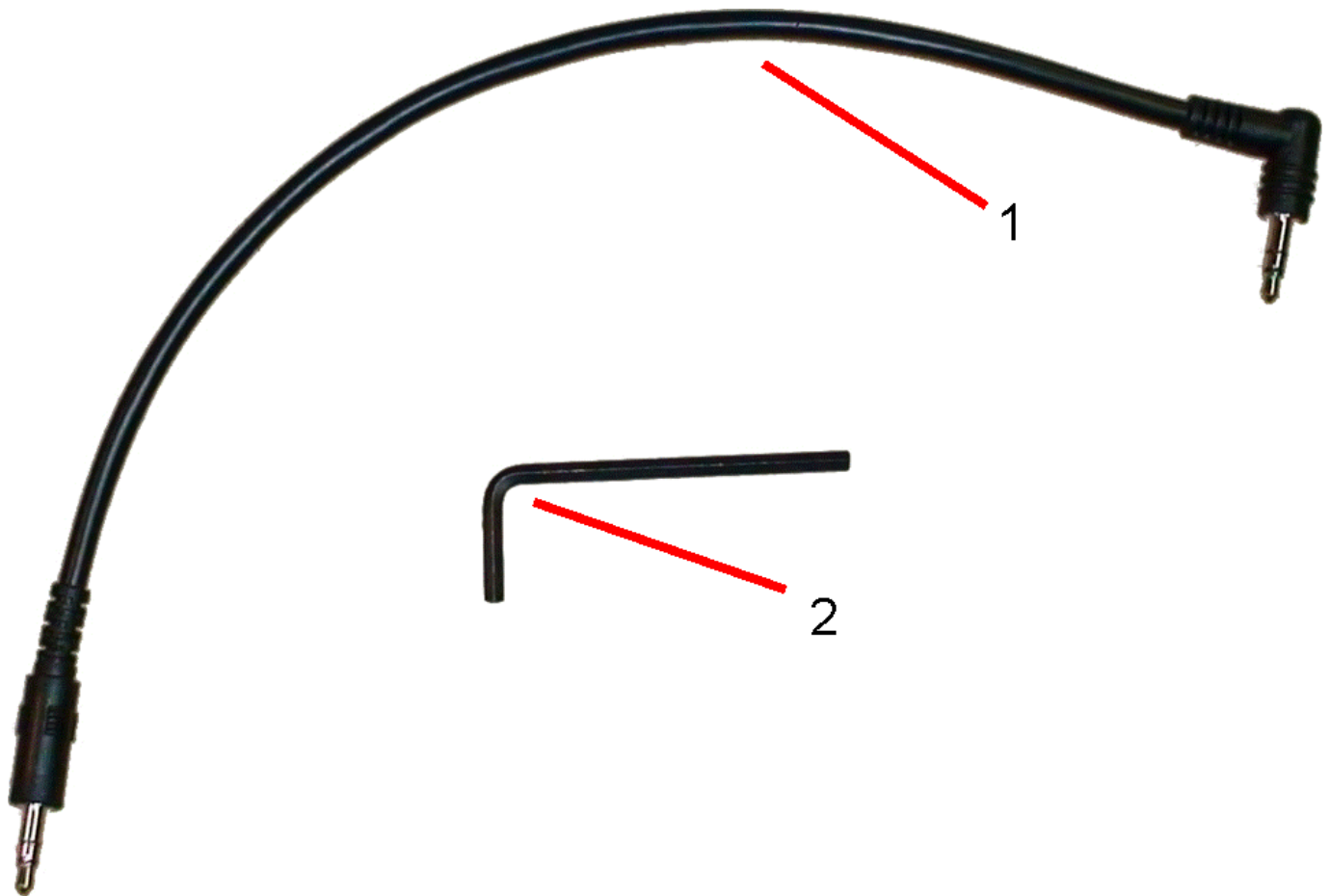

1. Stereo minijack cable. Use to connect mic output of DT454 to the mic input on the camera.
2. Hex key. USE HEX KEY TO TURN ¼-20 SCREW INTO CAMERA FOR MOUNTING TO BOTTOM OF CAMERA.

Return to [Contents](#)

## ***Accessories***

TBD

Return to [Contents](#)

## Block Diagram (Basic)

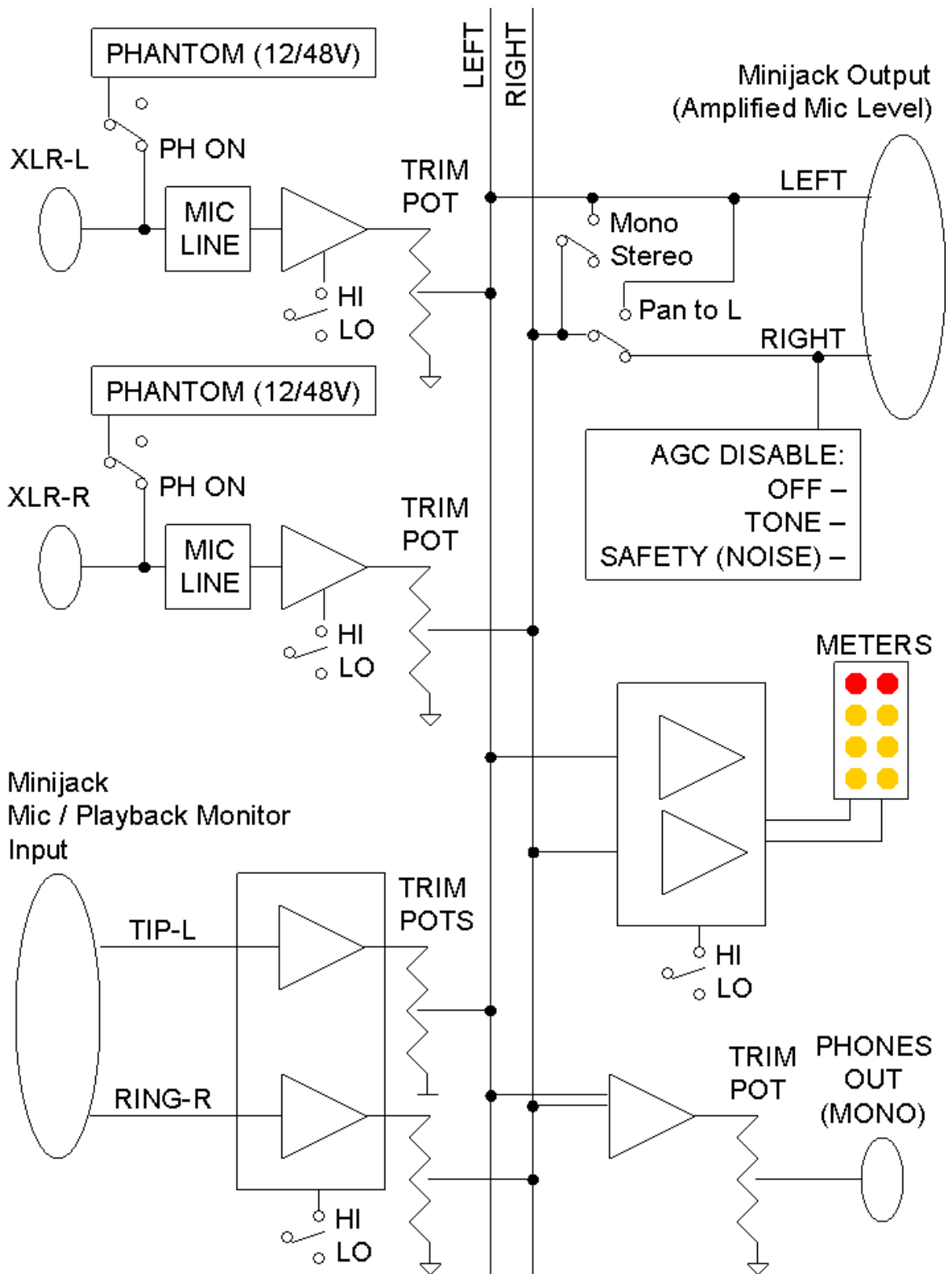

Return to [Contents](#)

## Basic Operation

### Mounting to Camera



Use the 1/8" Hex Key (included).

Insert the Hex Key into the bottom of the 1/4-20 mounting screw, and rotate the mounting screw into the 1/4-20 threads in the base of the camera.

The Hex Key provides leverage so the 1/4-20 mounting screw can be secured tightly.

Return to [Contents](#)

## Mounting to Tripod

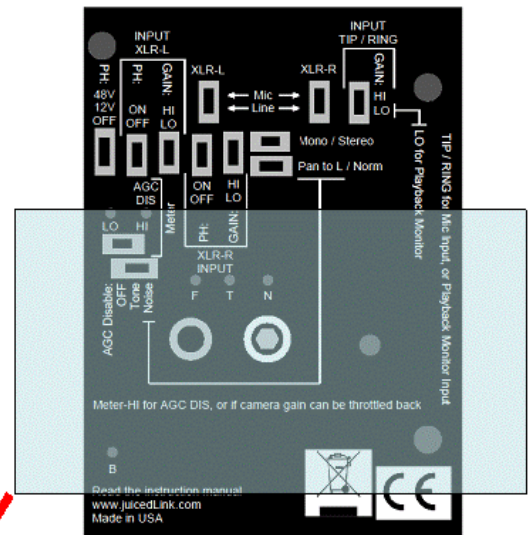
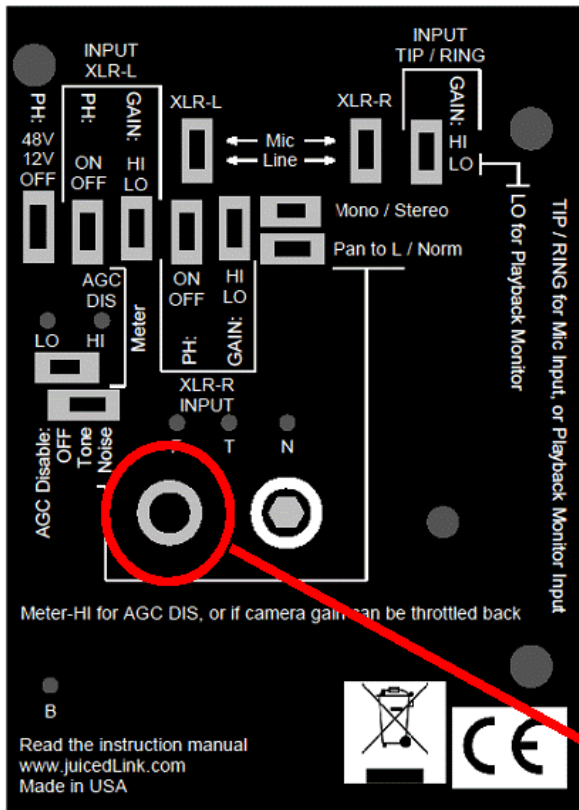

Approx size of Manfrotto quick-release mounting plate

1/4-20 Threads

The bottom of the DT454 has 1/4-20 threads for mounting to the top of a tripod, or other device.

Typically, users will mount their equipment to a quick release plate first.

The switch locations of the DT454 were designed such that the most frequently used switches (Gain, Phantom Power, and Panning) are most readily available to the user. The illustration shows what portion of the DT454 base is occupied by a typical quick release mounting plate (Manfrotto 357). The plate limits access only to items rarely used (sometimes, these are only used once at setup with your equipment).

Return to [Contents](#)

## Output Connection to Camera

To camera 3.5mm minijack mic input



Use the included 3.5mm stereo miniplug cable, and plug one end into the DT454 **OUT** jack. Then, plug the other end into the camera's 3.5mm minijack microphone input.

Note, some cameras may use 2.5mm plugs instead of 3.5mm plugs. Inexpensive adapters are available to make the required connection.

Return to [Contents](#)

## ***Powering***

Place a fresh 9V alkaline battery into the DT454 battery tray, using the correct orientation.

Flip the **PWR** switch to **ON**. The **PWR** indicator LED will illuminate.

When the battery starts to get so low, that you should change it, then the **LOW BATT** indicator LED will illuminate. This indicator is calibrated for alkaline type batteries.

Note, it is possible for a battery to be so dead, that it doesn't have enough juice to power the **LOW BATT** indicator circuitry or LED, but it can still illuminate the **PWR** LED. With such a nearly completely dead battery, the unit will not operate (even though the LED indicators may lead you to believe that it should).

## **Alkaline Battery Life**

Battery life varies, and depends on numerous factors. Use of phantom power takes up battery resources, especially at 48V. See the "Phantom Power" section for tips on optimizing power efficiency. Here are some ***estimates*** for ***typical*** continuous usage from a fresh 9V alkaline battery:

- No Phantom: ~7hrs
- With one 2mA mic @ 12V: ~5hrs
- With one 2mA mic @ 48V: ~2hrs

## **Rechargeable Batteries**

The iPowerUS 9V Lithium-Polymer is a good choice for a rechargeable battery:  
<http://www.ipowerus.com/Products/DC9V500/DC9V500.htm>

These are nice because of their high capacity, and fast recharge time. The higher capacity also extends battery life. Here is an ***estimate*** for ***typical*** continuous usage from a fresh battery of this type:

- With one 2mA mic @ 48V: ~5hrs

Return to [Contents](#)

## ***Input Connections***

The DT454 has facilities for individual control of 4 audio inputs.

### **TIP-L / RING-R Unbalanced Input**

*For details regarding Playback Monitoring, see the Playback Monitoring section.*

The **TIP-L / RING-R** is an unbalanced stereo minijack input, with individual **TRIM** controls for each, enabling two separate microphones to be controlled and used.

Unless otherwise reconfigured by the **PAN TO L** or **MONO** switches, **TIP-L** is routed to the left output channel, and **RING-R** is routed to the right output channel. This is illustrated in the Block Diagram section.

Multi-channel wireless microphone systems with separate microphones on the miniplug ring/tip output will interface directly into the **TIP-L / RING-R** minijack input. Unbalanced mics, such as the Rode VideoMic / Stereo VideoMic, also interface directly into the **TIP-L / RING-R** minijack input.

There may be occasions when you want to connect two mics which have their own mono miniplugs. This is easily accomplished with a Stereo 3.5mm Male to 2x Mono 3.5mm Female Y Cable (see Hosa part number YMM-261):



There may be occasions when you want to connect consumer-type devices with RCA unbalanced outputs. This can easily be accomplished with a Stereo 3.5mm Male to 2x RCA Female Y Cable (see Hosa part numbers YRA-167 and YRA-154):



## **XLR-L / XLR-R Balanced Input**

Unless otherwise reconfigured by the **PAN TO L** or **MONO** switches, **XLR-L** is routed to the left output channel, and **XLR-R** is routed to the right output channel. This is illustrated in the Block Diagram section.

Balanced sources, such as XLR balanced microphones, or line level signals from a balanced sound board, can be plugged directly into **XLR-L** and **XLR-R**.

See the sections on Phantom Power and MIC/LINE switches for more details.

## **XLR-L / XLR-R with Unbalanced Sources (Wireless, Etc.)**

**XLR-L** and **XLR-R** are capable of interfacing with unbalanced sources. However, the proper XLR connector must be used. This XLR connector must connect pin 1 with pin 3, which effectively grounds the balanced “cold” signal, where the balanced “hot” signal remains for connection with the unbalanced source.

Without this special connector which connects pin1 to pin3, the signal will not be processed by the DT454 balanced receiver, and the result is that there will be no output signal for this input.

**WARNING:** Do not apply phantom power to any of these connectors which connect pin1 to pin3. You will be shorting out the phantom voltage, and can potentially damage your equipment.

Here are some examples of connectors which connect pin 1 to pin 3.

Rode VXMLR:



Hosa GXM133:



Return to [Contents](#)

### ***Phantom Power***

Condenser microphones require a voltage to operate. Some will take their own battery. Others require that a voltage is generated by the mixer that the microphone is plugged into, and that voltage gets transmitted up the microphone cable to power the condenser microphone element. This is what is known as “phantom power”.

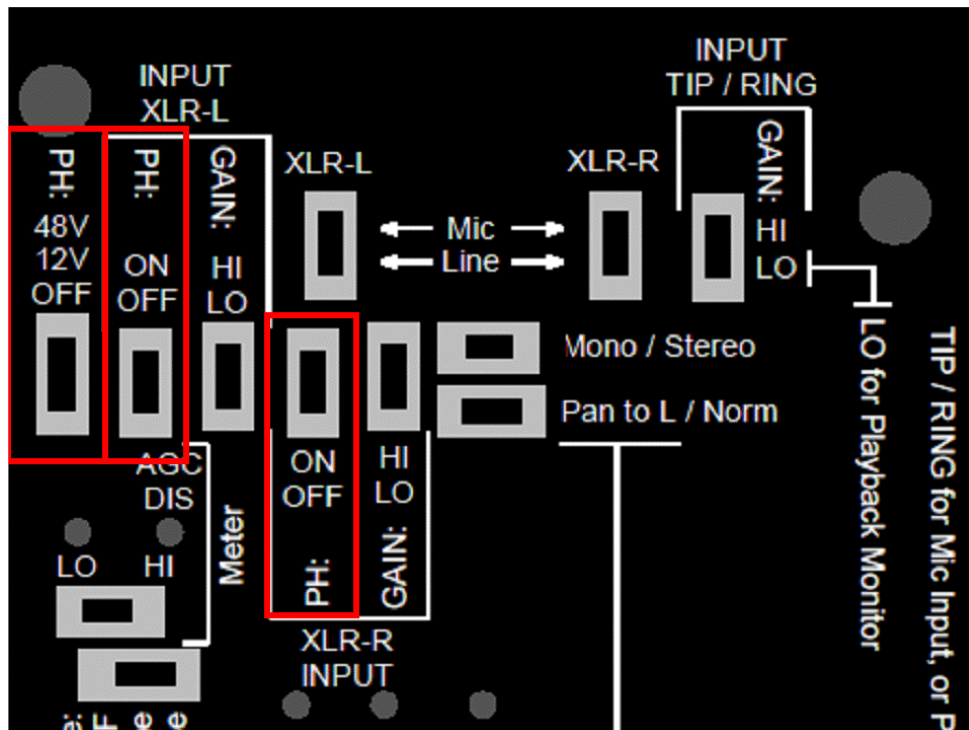

1. Choose what function the phantom power generator circuit should perform by selecting **PH: OFF / 12V / 48V** on the selector switch.
2. Route the voltage produced by the phantom power generator circuit to the XLR input which requires phantom power with **PH: ON / OFF** switch for the corresponding **XLR-L** or **XLR-R** input.

The DT454 does not provide T-Powering.

#### General Phantom Power Microphone Tips:

- If you are in the market for new microphones, then consider:
  - A microphone that works from phantom power only will be much shorter and lighter since it does not have the added weight/length for the battery, making it easier to boom or mount to camera (when necessary).
  - Consider a microphone that will work down to 12V phantom power. This will considerably extend the battery life of the DT454. There are many excellent modern microphones with this capability.
- If your microphone will work from a battery already, then operate the microphone from the battery instead of phantom power. This is much more power efficient for the system, and will result in longer battery life. In some cases there are differences in the mic performance between phantom power and battery power. But, these differences are negligible, and mostly have to do with the maximum SPL handling capability of the microphone (which is not a very important parameter for general use).
- Check out more information about battery life in the “Powering” section.

Return to [Contents](#)

## MIC/LINE Switches

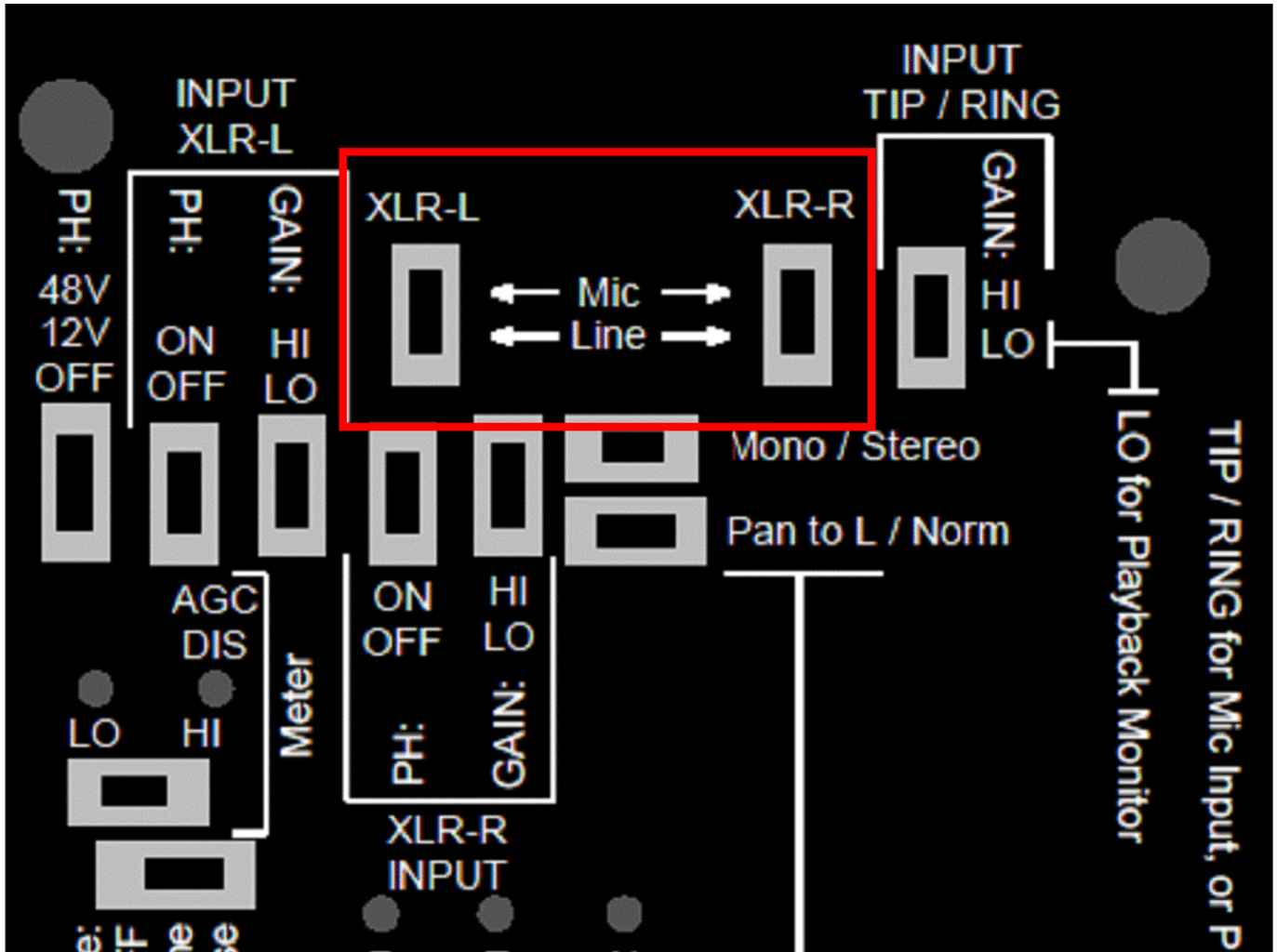

The **LINE** position inserts a 40dB attenuator before the preamps in the **XLR-L** and **XLR-R** signal chains.

For typical microphone use, the **MIC** position is selected.

Return to [Contents](#)

## **MONO / STEREO Switch**

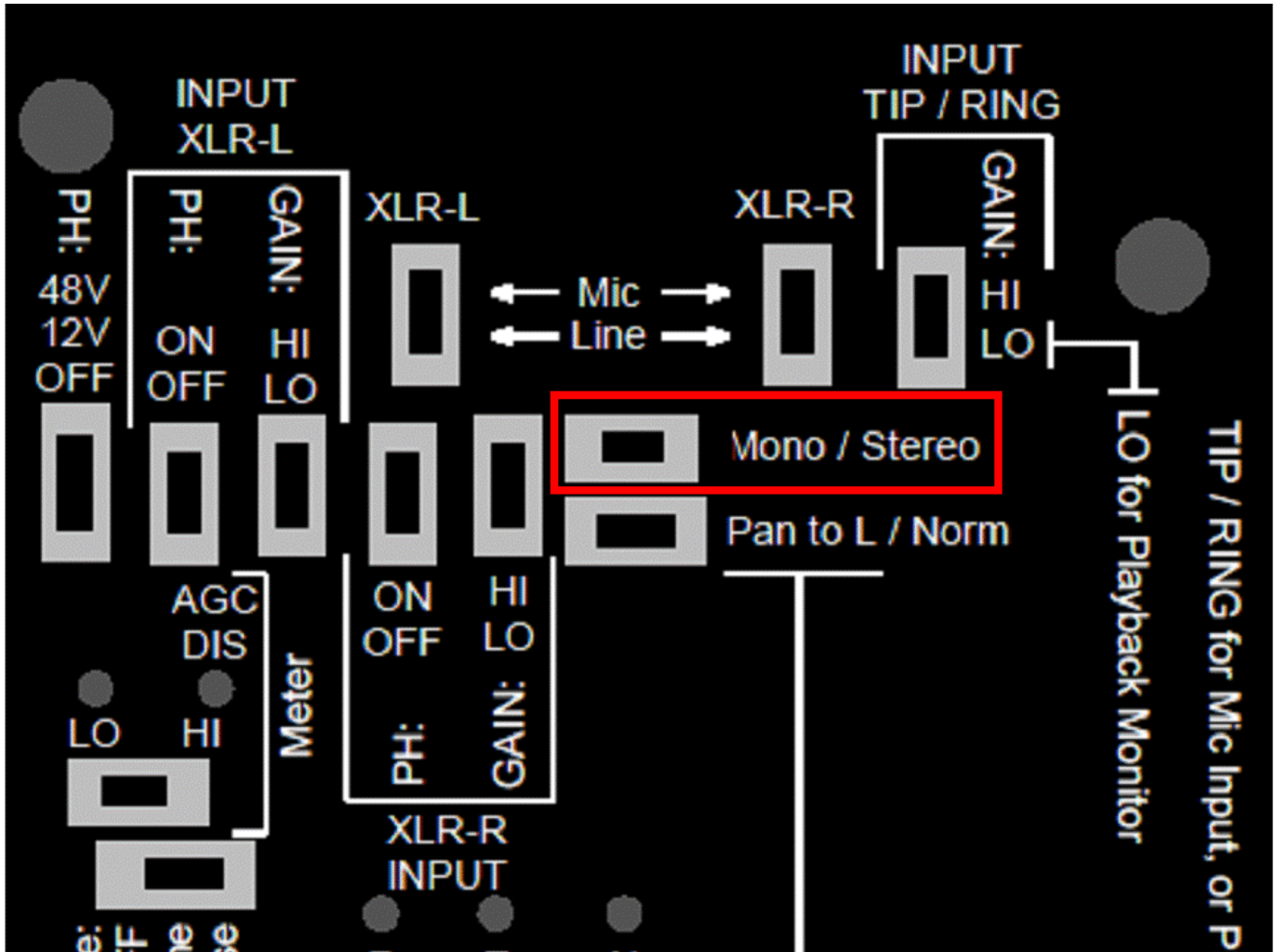

As illustrated by the Block Diagram, the **STEREO** switch position keeps the right and left signal channels independent from each other, and presents them to the corresponding right and left output connections of the **OUT** minijack.

The **MONO** switch position combines the right and left signals, and presents the combination to both the right and left output connections of the **OUT** minijack. This can save a small step in post production when using a single mono mic.

Note, the **MONO** switch position will result in a loss of some gain because of the loading effect. The DT454 has sufficient maximum gain to make up for this loss in most circumstances.

Return to [Contents](#)

## ***PAN TO L / NORM***

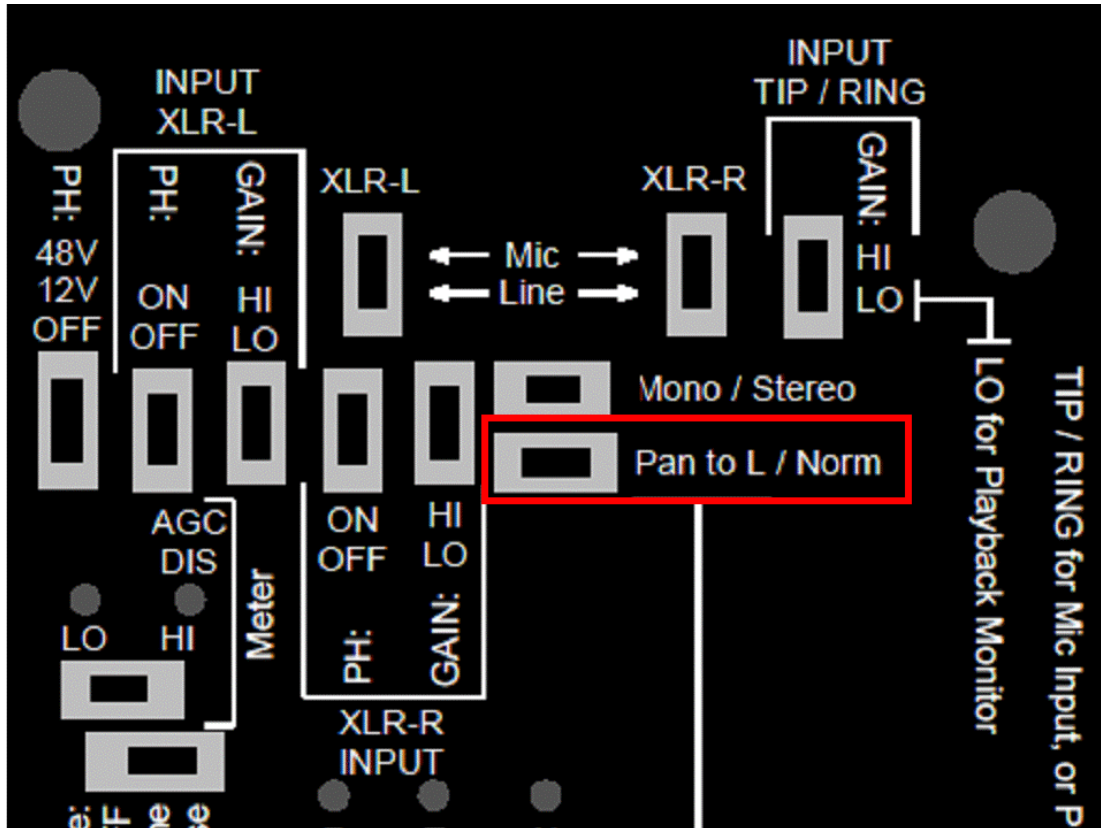

As illustrated by the Block Diagram, the **PAN TO L** switch position routes the right channel over to the left channel. So, **PAN TO L** is used to route **XLR-R** and **RING-R** to the left channel for recording.

This is utilized when you are using right channel mics (**XLR-R** or **RING-R**), and plan on abandoning the track containing the **TONE** or **NOISE** AGC Disable signal track (right). Note, when using the **NOISE** AGC Disable signal, you must abandon the right recording track.

See more details in the AGC Disable section.

Return to [Contents](#)

## **GAIN Settings**

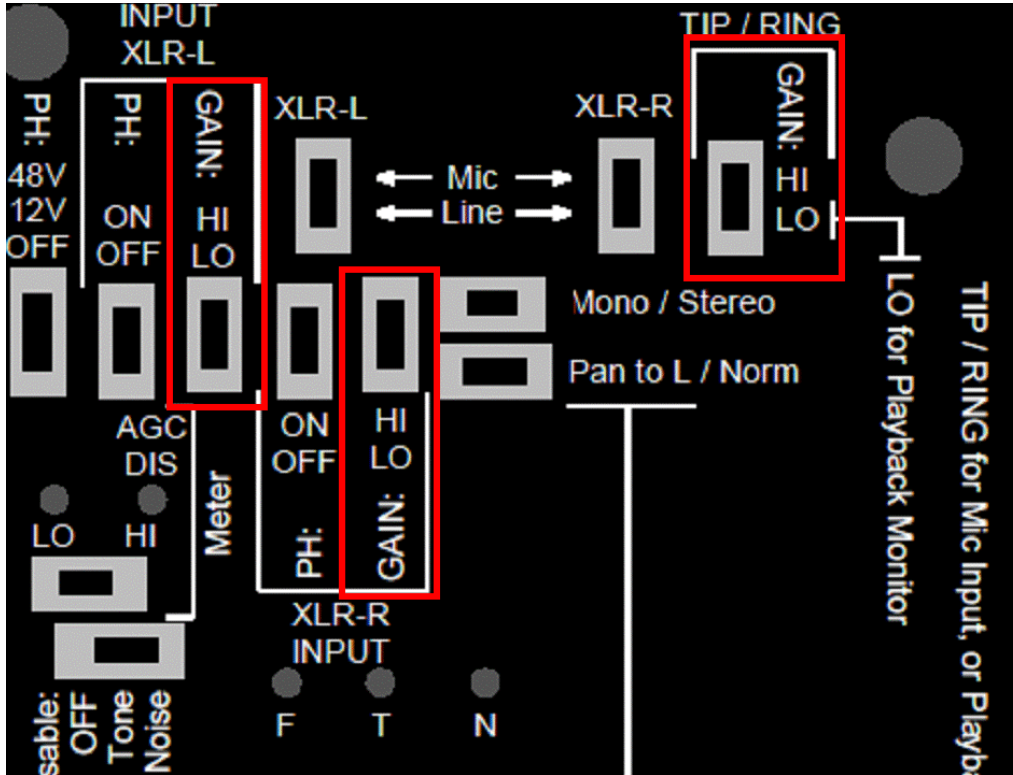

The Block Diagram illustrates where the low-noise preamplifiers are located in the system. Note that the two low-noise preamps for the **TIP-L** and **RING-R** inputs have their gain settings controlled by one switch (so both will either be **HI** or **LO**).

When setting up, the user will typically start with the **GAIN** in the **HI** position. If you find that the correct level settings (see Meter section) require use of the **TRIM** potentiometers (volume control knobs) near the full counter-clockwise position (where small changes in the potentiometer position result in large changes in signal, because of the logarithmic nature of audio pots), then you can switch the **GAIN** to the **LO** position (to get back into the sweet spot of the potentiometer's adjustment range).

Check out the “Metering” section for more details for appropriate level settings.

For Playback Monitor settings, see the Playback Monitor Section.

Return to [Contents](#)

## **TRIM Potentiometers**

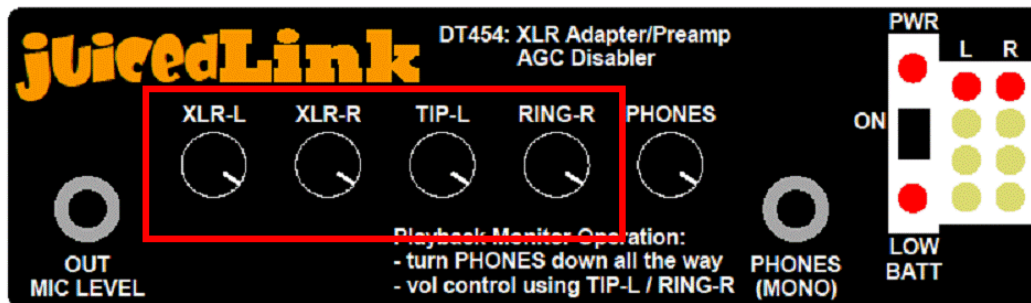

The Block Diagram illustrates where the **TRIM** potentiometers (volume control knobs) are located in the system.

When setting up, the user will typically start with the **GAIN** in the **HI** position. If you find that the correct level settings (see Meter section) require use of the **TRIM** potentiometers (volume control knobs) near the full counter-clockwise position (where small changes in the potentiometer position result in large changes in signal, because of the logarithmic nature of audio pots), then you can switch the **GAIN** to the **LO** position (to get back into the sweet spot of the potentiometer's adjustment range).

Check out the “Metering” section for more details for appropriate level settings.

Return to [Contents](#)

## ***Camcorder Settings***

Consult the camera User Manual to learn what audio controls are provided. It is preferred that cameras have manual override of their Automatic Gain Control (AGC), with control of the gain. Some cameras do not have full control of the gain, but provide a “High” and “Low” setting. Others have no manual override of the AGC at all.

### **Low-Noise Performance**

The general principle to improve your signal-to-noise performance is to throttle back the noisy camera amplifiers, and replace that noisy gain with clean gain from the juicedLink low-noise preamplifier.

This results in an improved signal-to-noise performance while recording fine audio detail, such as dialogue.

***Make sure you turn down all of the TRIM potentiometers on the DT454 which do not have a microphone connected to its input.*** Preamps without the impedance of a microphone connected to their input, have a high impedance at the preamp input, which results in the preamp generating a lot of noise. So, turn down all of the **TRIM** potentiometers on the DT454 which do not have a microphone connected to its input.

If your camera does not have manual controls, then see the “AGC Disable” section for more details.

### **Dynamic Range Performance**

When you are in an unpredictable signal level environment (say, a birthday party where kids could suddenly scream), then it is best to utilize the AGC in the camera to provide you with the widest dynamic range of overload protection.

Fortunately, in such environments (like a birthday party), the ambient noise level is high enough where you do not need to push your equipment to achieve its best available signal-to-noise performance anyway.

Use the camera’s automatic/AGC setting, and set the **METER** to the **LO** position. See the “Metering” section for more details.

Return to [Contents](#)

## AGC Disable

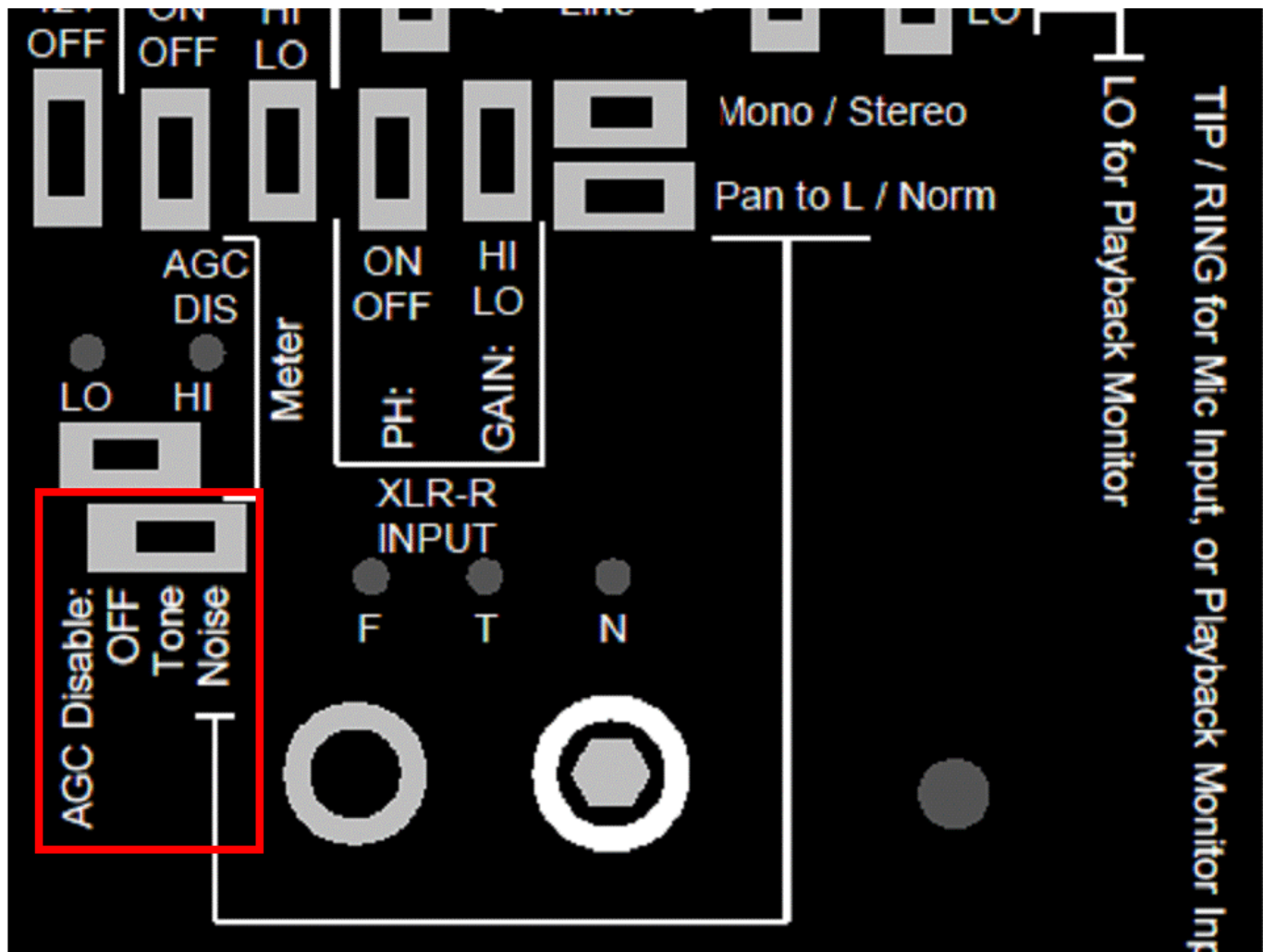

For cameras which do not have any manual override of their AGC (Automatic Gain Control), the DT454 offers 2 methods to defeat the AGC.

Signal-to-noise is improved when noisy camera amplifiers are throttled back, and the noisy camera gain is replaced by clean gain in the juicedLink low-noise preamplifiers. This is easily accomplished with cameras having manual control of audio gain (see the “Low Noise Performance” section).

However, some cameras do not have manual control. The DT454 AGC Disable feature forces the camera’s AGC to throttle back its noisy gain by sending a signal (either **NOISE** or **TONE**) into the camera’s right channel (as illustrated by the Block Diagram), to improve signal-to-noise performance. The camera senses the presence of a strong signal in the right track, and the camera’s AGC function then throttles back its noisy gain.

Even with the AGC Disable technique, there are limitations in usability and performance. The technique greatly improves signal to noise performance, taking what was unusable audio, and providing you with something that you can work with. But, it generally will not provide as high quality signal-to-noise performance compared to a camera which already has manual controls. Additionally, there is a good chance that you will have to abandon one of your recording tracks (the camera's right channel where the AGC Disable signal is routed). If you have not yet selected a camera, we recommend that you consider one which already has manual control of its audio.

## Tone

The **TONE** setting injects a ~20KHz tone into the right recording track of the camera.

This frequency is selected since it is beyond the audible range for most people, and is an attempt to continue to use the camera's right track for recording. This may work OK on some cameras, and may not work at all on other cameras.

Continued use of the right recording track depends on the camera's Nyquist Anti-Aliasing Low-Pass Filter to be working extremely effectively. Otherwise, the inaudible ~20KHz tone can produce aliased artifacts *in the audio band*. You will need to run tests to validate the effectiveness of this approach with your equipment. Evaluation of these tests must be done with the clip pulled into your computer or with playback monitoring, since the headphone monitoring takes place *before* the recording device.

If the evaluation of recorded audio is not to your satisfaction, then you will either abandon the right recording track while using the **TONE**, or use the Safety Mode – **NOISE** approach. In either case, if you are using right channel microphones (**XLR-R** or **RING-R**), then you will use the **PAN TO L** switch to route those mics to the clean recording channel (left).

If you are going attempt to use the right recording track, then you should test this out before each shot. Some AGC algorithms which not only change their gain settings, but also play around with filter roll-off frequency settings. This not only effects aliasing which can produce in-band tone effects, but also creates audible pops and clicks as the parameters get adjusted by the firmware.

We are risk averse when it comes to production audio. If you are forced to use an AGC Disable technique because your camera does not have manual control, then we are of the opinion that even if you choose to use the **TONE** approach, you should abandon the camera's right track, and only use the clean left track for recording. Then use the **PAN TO L** switch to route any right channel microphones (**XLR-R** or **RING-R**) to the clean left recording track. See the "Post-Production: Removing Right Track" section for more details.

If you do attempt to use the right track, then the ~20KHz tone will also be recorded with your audio on the right track. Even though this ~20KHz tone is inaudible for most people, ***you should take the extra step to remove this tone in post production.*** Your final product may get resampled by a compression algorithm that you don't control (YouTube, etc) and result in an aliased artifact of the *tone back in the audio band*. See the "Post Production: Removing Tone" for more details

With either the **TONE** or **NOISE** approach, you will use the **METER** in the **HI** setting. The meter sensitivity has been pre-calibrated for a typical camera. If further calibration is desired, then see the "Meter" section for more details

### Safety Mode – Noise

The **NOISE** setting injects a broadband uncorrelated noise signal into the right recording track of the camera. This leaves the left track clean for recording:

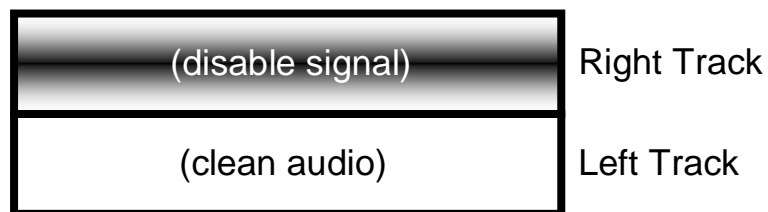

As such, you will **NOT** be able to use the right track of the camera to record your microphones.

If you have any microphones plugged into the right input channels (**XLR-R** or **RING-R**), then you must use the **PAN TO L** switch to route those signals over to the left output channel.

Although you sacrifice one recording channel, the **NOISE** approach is a much more stable and repeatable technique for **AGC DISABLE**.

However, another valid approach would be to use the **TONE**, and abandon the right track just the same. You may want to test out each approach, to see what works best with your system.

In post, you will need to **delete the right track of audio containing the disable signal**. See the “Post Production – Removing Right Track” for more details.

**Special note regarding Canon Cameras:**

1. The microphone input on the camera does not get activated until the camera begins to RECORD for the first time.
2. Until you hit RECORD and activate the microphone input, you will hear noise in the DT454 headphones. Once you hit RECORD, the noise in the headphones goes away, and doesn't return until the camera power gets cycled.
3. After the camera power gets cycled, you will need to hit RECORD again to eliminate the noise in the headphones.

With either the **TONE** or **NOISE** approach, you will use the **METER** in the **HI** setting. The meter sensitivity has been pre-calibrated for a typical camera. If further calibration is desired, then see the “Meter” section for more details

Return to [Contents](#)

## ***Metering: Setting the Appropriate Gain/Trim Levels***

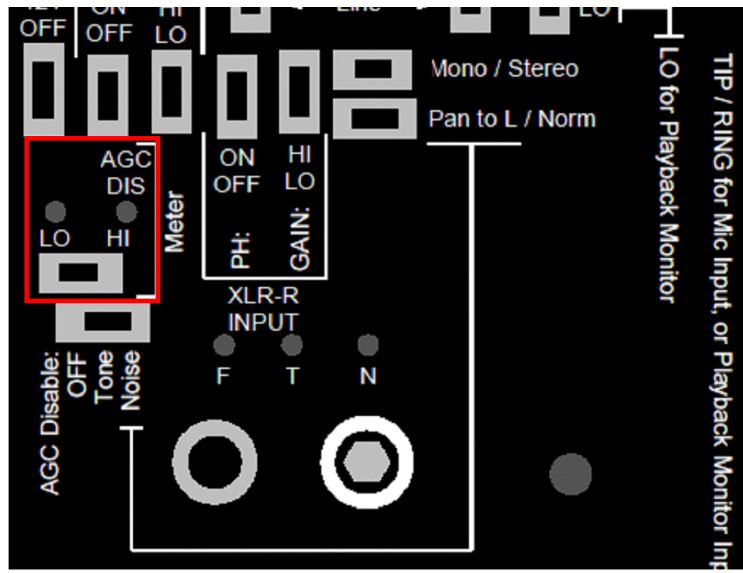

Whenever your camera has its own meters, the camera meters are the final arbiter for the appropriate level settings.

The meter on the DT454 will be used so that the signal peaks splash into the 3<sup>rd</sup> amber LED, but do not hit (or, infrequently hit) the 4<sup>th</sup> red LED. But, the correct meter settings for the corresponding situation must be used.

The bottom of the unit has a **METER** switch.

The **METER LO** position has been calibrated for a typical camera with its AGC in operation. When you want to optimize dynamic range instead of noise performance, then you will want to take advantage of the camera's AGC. See the "Dynamic Range Performance" section for more details.

The **METER HI** position has been calibrated for a typical camera using one of the **AGC DISABLE** approaches, or a camera whose gain has been manually throttled back. See the "Low Noise Performance" and "AGC Disable" sections for more details.

For a camera which has manual control, throttling the gain to about 1/3 full gain is a good place to start. Different cameras may have a different sweet spot for lowest noise performance with decent dynamic range. You will have to conduct some recording tests to experiment.

Some cameras do not have a meter, and only coarse granularity of manual control (such as a "low", "medium", and "high" setting). Start with your camera's "low"

setting, and conduct some tests where your audio signal on the DT454 meter peaks splash into the 3<sup>rd</sup> amber LED, but do not hit (or, infrequently hit) the 4<sup>th</sup> red LED.

If your camera has a meter, then follow these steps to get started:

1. Connect a mic to your DT454, and adjust the **GAIN** and **TRIM** (volume potentiometer) settings so that when you speak into your microphone, the meter peaks splash to the 3<sup>rd</sup> amber DT454 LED, without illuminating the 4<sup>th</sup> red LED (or infrequently doing so).
2. Throttle back the camera gain, until the peaks splash just past the -12dB full scale meter reading on the camera. Now your DT454 and camera meters (for the given camera setting) are calibrated.

Check to see if your camera is listed in the “Notes on Specific Cameras” section.

**Make sure you turn down all of the TRIM potentiometers on the DT454 which do not have a microphone connected to its input.** Preamps without the impedance of a microphone connected to their input, have a high impedance at the preamp input, which results in the preamp generating a lot of noise. So, turn down all of the **TRIM** potentiometers on the DT454 which do not have a microphone connected to its input.

If it is desirable to adjust the meter sensitivity, there are adjustment potentiometers behind the holes in the bottom of the enclosure next to the **HI** and **LO** markings which provide a limited adjustment range.

Return to [Contents](#)

## ***Headphone Monitoring***

As illustrated by the Block Diagram, the headphones output a mono signal, combining both the right and left channels into each of the headphone earcups.

At high gain, the small consumer-grade headphone amp can produce a lot of noise. Fortunately, for most circumstances where the camera gain has been throttled back (either manually, or by the AGC Disable feature), the signal level is relatively high, so the headphone gain can be turned down where the headphone amp noise is relatively low.

Return to [Contents](#)

## ***Playback Headphone Monitoring***

As illustrated by the Block Diagram, the headphones output a mono signal, combining both the right and left channels into each of the headphone earcups.

To use the headphone amplifier for playback monitoring, set the DT454 with the following configuration:

- **TIP-L / RING-R GAIN** set to **LO**
- Turn down the **PHONES** volume control all of the way.
- Use the **TIP-L / RING-R TRIM** (volume control knobs) as the volume control for the headphones.

Plug the camera's AVout into the DT454 **TIP-L / RING-R** input. The AVout jack has 4 contacts, so you can't use a standard 3 contact stereo miniplug cable. Custom cables can be made. Alternatively, many cameras come with an AVout to RCA cable. You can use an inexpensive Stereo 3.5mm Male to 2x RCA Female Y Cable (see Hosa part numbers YRA-167 and YRA-154):



If the **NOISE** AGC Disable approach was used, then simply do not plug in the right (red) channel, since this will be abandoned anyhow.

Return to [Contents](#)

## Notes on Specific Cameras

### Canon 5D Mark II

#### Firmware Release 2.0.4

With firmware release 2.0.4, Canon has provided manual control for audio!!! It also provides for a meter. But, the meter is only visible during setup (not during recording).

This is a welcome addition. We hope to see firmware updates from all DSLR manufacturers, for all cameras to add audio features. This is what people want ...

For lowest noise performance while recording fine audio detail, you will want to manually throttle back the camera gain, and replace that noisy gain with clean gain from the juicedLink low-noise preamplifier. Follow the directions from Canon for how to navigate the firmware menus.

To get started with a setup for low-noise performance, follow these steps:

1. Connect a mic to your DT454, and adjust the **GAIN** and **TRIM** (volume potentiometer) settings so that when you speak into your microphone, the meter peaks splash to the 3<sup>rd</sup> amber DT454 LED, without illuminating the 4<sup>th</sup> red LED (or infrequently doing so).
2. Throttle back the camera gain, until the peaks splash just past the -12dB full scale meter reading on the camera. This is usually around clicks 3-6 (above the lowest (off) setting). At this setting, the camera and DT454 meters are calibrated.

This provides for reasonably good low-noise performance.

However, the lowest noise performance will be achieved with the lowest gain setting on the 5D (1 click above the lowest (off) setting). This may be just a little outside the factory calibration for the DT454 **METER HI** setting. You can run the DT454 meter a little hot. Or, you can try and get the DT454 calibration a little bit closer to the 5D 1-click setting:

1. Set the 5D gain on the 1-click (above off) setting
2. Connect a mic to your DT454, and adjust the **GAIN** and **TRIM** (volume potentiometer) settings so that when you speak into your microphone, the meter on the 5D peaks splash up to the -12dB full scale point.
3. Use a small screwdriver in the hole that is next to the **HI** setting switch, and rotate the potentiometer counterclockwise to get the calibration closer. The

meter has a limited calibration range, but you should be able to get the correlation fairly close.

## **MagicLantern 3<sup>rd</sup> Party Firmware**

MagicLantern is 3<sup>rd</sup> party firmware that was written by a genius for the 5D platform. It is not from Canon, so you need to do your due diligence to understand the risks of what you are getting yourself into. It has very useful tools and has a lot of users (you can converse with the users on the typical video production message boards), but as it is not from Canon, it is not a solution for everybody.

However, MagicLantern provides for even more control than the Canon firmware does. It has meters that are always visible, so those will be the final arbiter for level settings. It allows you to control the camera's analog gain (the Canon firmware throttles back the digital gain), so you can achieve even lower signal-to-noise performance with a 5D running MagicLantern being fed by juicedLink low-noise preamplifiers. Since the DT454 has even more available gain than the juicedLink CX family of preamps, the 5D analog gain can be set to 0dB gain, for even lower noise performance than was even achievable before.

## Advanced Topics

### Post Production – Removing Tone

Even though this ~20KHz tone is inaudible for most people, **you should take the extra step to remove this tone in post production**. Your final product may get resampled by a compression algorithm that you don't control (YouTube, etc) and result in an aliased artifact of the *tone back in the audio band*.

#### 1. Audacity

- a. This technique utilizes the Nyquist plug-in for Audacity called “Notch”.
  - i. Download and install the plug-in here:  
<http://audacity.sourceforge.net/download/nyquistplugins>
  - ii. You will need to restart Audacity after the plug-in is placed in the proper directory
- b. Measure the exact tone frequency in your clip
  - i. Use your mouse to select the waveform in the right track
  - ii. ANALYZE > PLOT SPECTRUM will bring up a frequency analysis window of your waveform
  - iii. Change the number of samples from 512 to 2048
  - iv. Move the cursor over the ~20KHz tone, and note the frequency
- c. Use “Notch” to knock down the tone amplitude
  - i. Use your mouse to select the waveform in the right track
  - ii. EFFECT > NOTCH FILTER brings up the “Notch” program
  - iii. Change the “Default Choice” to “2”. This allows you to enter your own custom notch frequency
  - iv. Change the notch frequency to the frequency you noted from the plot of the frequency spectrum, above.
  - v. Set the notch Q to 1
  - vi. Click OK
- d. See that the tone amplitude has been knocked down
  - i. Use your mouse to select the waveform in the right track
  - ii. ANALYZE > PLOT SPECTRUM will bring up a frequency analysis window of your waveform
  - iii. Notice the tone amplitude is now knocked down

Return to [Contents](#)

## ***Post Production – Removing Right Track***

The **NOISE** setting injects a broadband uncorrelated noise signal into the right recording track of the camera. This leaves the left track clean for recording:

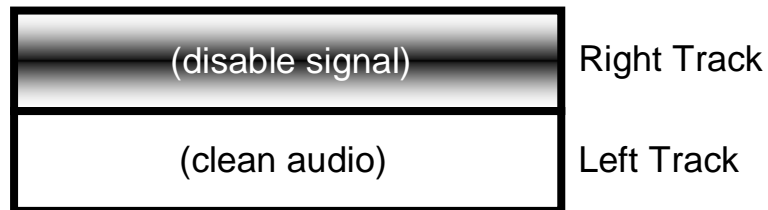

As such, you will *NOT* be able to use the right track of the camera to record your microphones. You may have also determined that you wish to use the **TONE** AGC Defeat signal, and abandon the right recording track just the same.

In post, you will need to ***delete the right track of audio containing the disable signal.***

2. Sony Vegas
  - a. Right click on the audio track
  - b. Select Channels
  - c. Select Left Only for the final mix
3. Final Cut / Express
  - a. Delete the right track
    - i. Modify > Link to unlink the audio from video
    - ii. Modify > Stereo Pair to unlink the right and left audio tracks
    - iii. Use mouse and select the right track
    - iv. Delete the right track
  - b. Copy the left track to the right track position
    - i. Make sure the “Auto Toggle” icon (the icon to the right of the “lock audio track” icon) for the right track is the only “Auto Toggle” icon activated
    - ii. Use mouse to select the left track
    - iii. Copy
    - iv. Paste. Since the right track is the only track with the “Auto Toggle” icon activated, it will paste into this track
    - v. You may need to select the right edge of the pasted audio track and expand (stretch) the track to fill the rest of the timeline
4. Final Cut / Express – Alternate Instructions
  - a. Delete the right track
    - i. Drag clip into timeline and select it with your mouse

- ii. MODIFY > LINK to unlink the audio from the video
  - iii. MODIFY > STEREO PAIR to unline the right and left audio tracks
  - iv. Use mouse to select and delete the right track
- b. Pan the left track to center
- i. Select (double click) the remaining left (A1) track
  - ii. "Pan" should currently read "-1"
  - iii. Click the slider and move it towards the center so it reads "0"
  - iv. Enjoy your clean audio!

Return to [Contents](#)

## **Appendix**

### **Subscribe to the juicedLink Blog**

Get notified on new revisions of this User Manual, product updates, new product releases, and tutorial videos. Subscribe to the blog:

[www.juicedlink.com/blog/index.html](http://www.juicedlink.com/blog/index.html)

Return to [Contents](#)

### **Care and Maintenance**

There is no specific maintenance regimen recommended.

Return to [Contents](#)

### **Warranty, Service, and Returns**

The design of the juicedLink family of ultra portable mixers is uncompromising in quality and performance, and utilizes top grade professional components. We are proud of our product, and are committed to servicing you to make your customer experience positive.

The *Policies* page on the juicedLink.com website describes the details of the conditions for returns, limited one year warranty, and instructions for obtaining service for your product.

Return to [Contents](#)

### **Compliance**

This device falls under the classification of FCC part 15, subpart B, section 15.103. Please refer to the FCC part 15 manual for details on conditions of operation.

This device has also been tested to meet CE certification standards.

Return to [Contents](#)